

End of the year show

#1 Showmanship Beginner.

Show Date: 09-28-2024

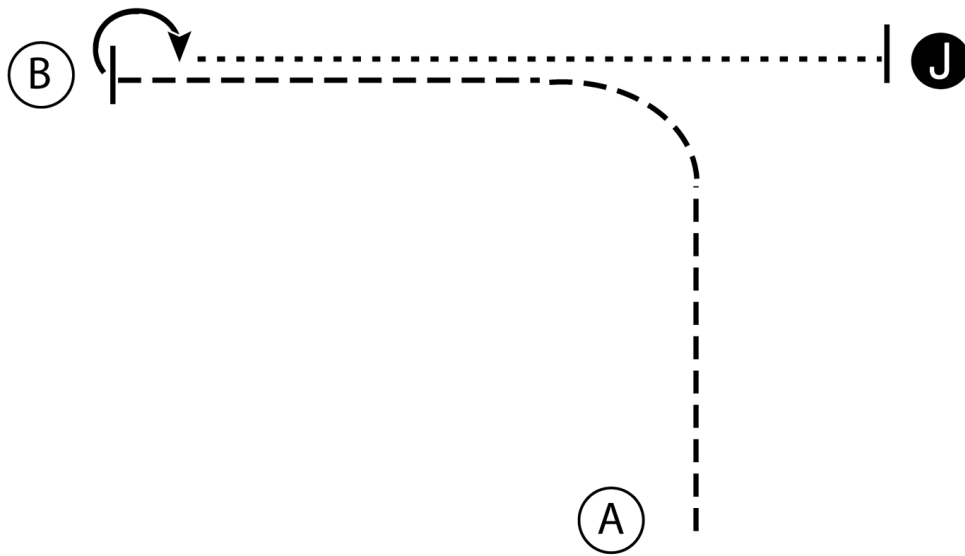

1. Trot from A to B.
2. Stop and perform a 180 degree turn.
3. Walk to Judge and set up for inspection.
4. When dismissed follow instructions of ring steward.

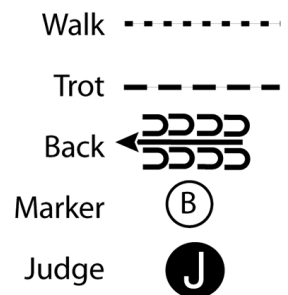

[S/1-11]

Pattern Provided by:

Silverado Western Riders

End of the year show

#2 Showmanship Open

Show Date: 09-28-2024

w w w . H o r s e S h o w P a t t e r n s . c o m

w w w . H o r s e S h o w P a t t e r n s . c o m

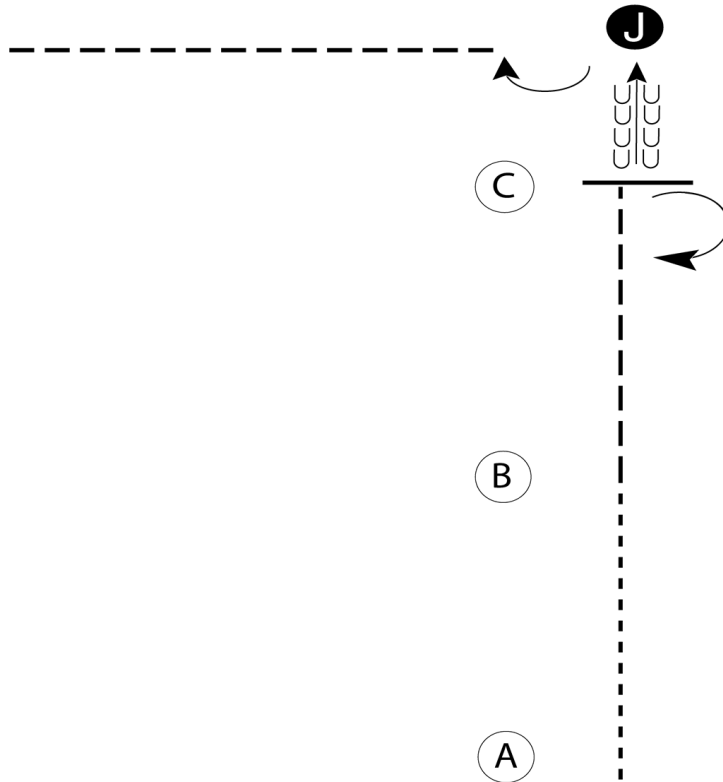

1. Walk from A to B.
2. Trot from B to C.
3. Stop at C and perform a 180 degree turn.
4. Back to Judge, set up for inspection.
5. When dismissed perform a 90 degree turn and trot straight away from Judge.

- Walk - - - - -
- Trot - . - . -
- Back ← — — — — —
- Marker (B)
- Judge (J)

[S/2-6]

Pattern Provided by:

Silverado Western Riders

End of the year show

#6 WesternHorsemanship W/T

Show Date: 09-28-2024

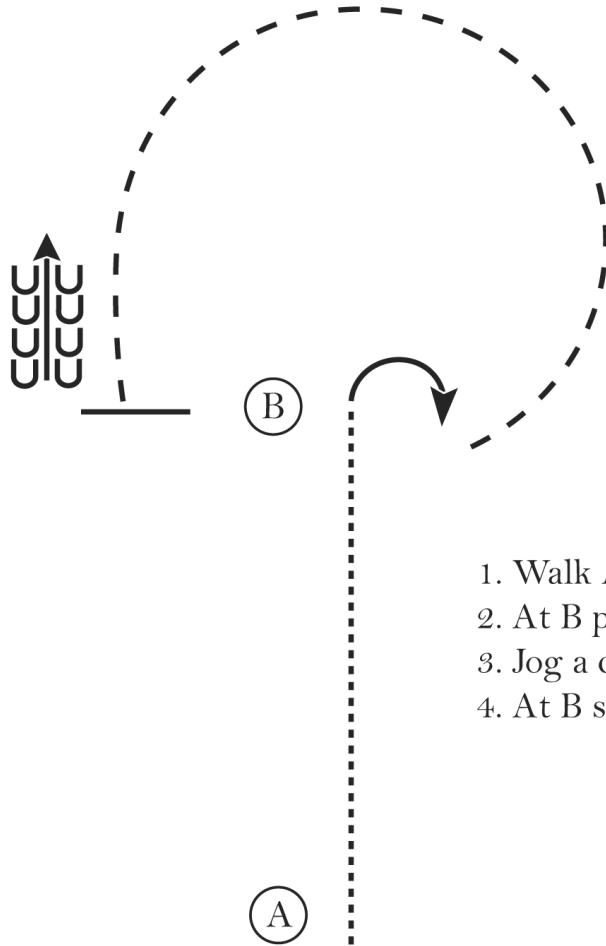

1. Walk A to B
2. At B perform a 90 degree turn to the right
3. Jog a circle around B
4. At B stop and back 4 steps

Walk
Jog	-----
Extended Jog	-----
Lope	————
Leg Yield	
Lead Change	↘
Back	←←←←
Marker	(B)
Sidepass	←←←←

[WH/WT-7]

Pattern Provided by:

Silverado Western Riders

End of the year show

#7 Western Horsemanship Beginner

Show Date: 09-28-2024

www.HorseShowPatterns.com

www.HorseShowPatterns.com

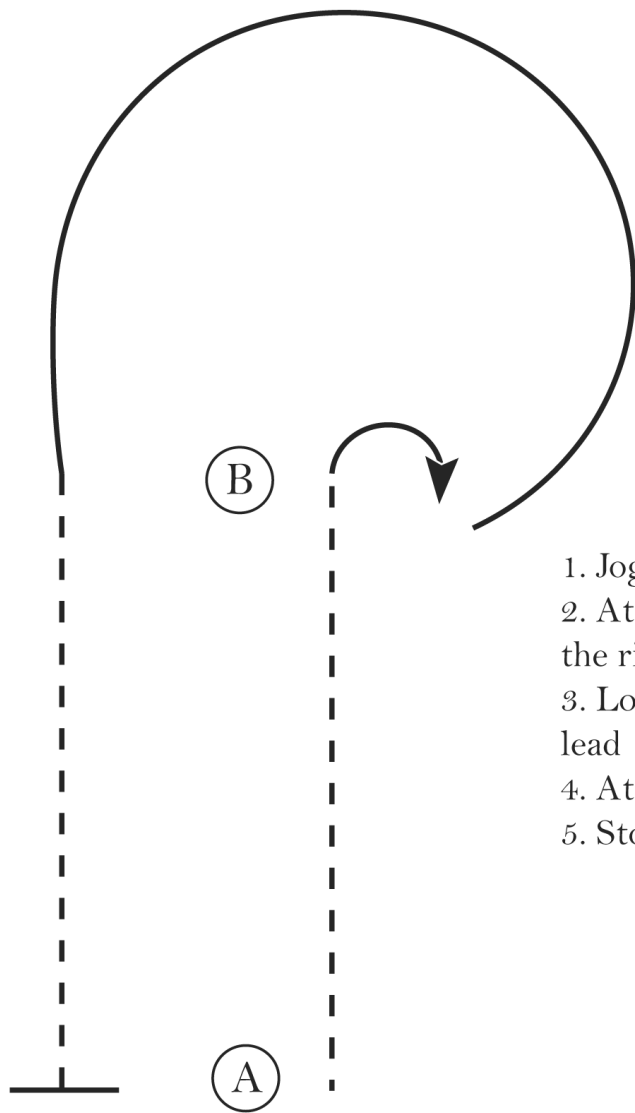

1. Jog A to B
2. At B perform a 90 degree turn to the right
3. Lope a circle around B on the left lead
4. At B jog to A
5. Stop at A.

Walk
Jog	- - - - -
Extended Jog	- - - - -
Lope	—————
Leg Yield	
Lead Change	↙ ↘
Back	←←←←←
Marker	(B)
Sidepass	←←←←←

[WH/1-14]

Pattern Provided by:
Silverado Western Riders

End of the year show

#8 Western Horsemanship Open

Show Date: 09-28-2024

w w w . H o r s e S h o w P a t t e r n s . c o m

w w w . H o r s e S h o w P a t t e r n s . c o m

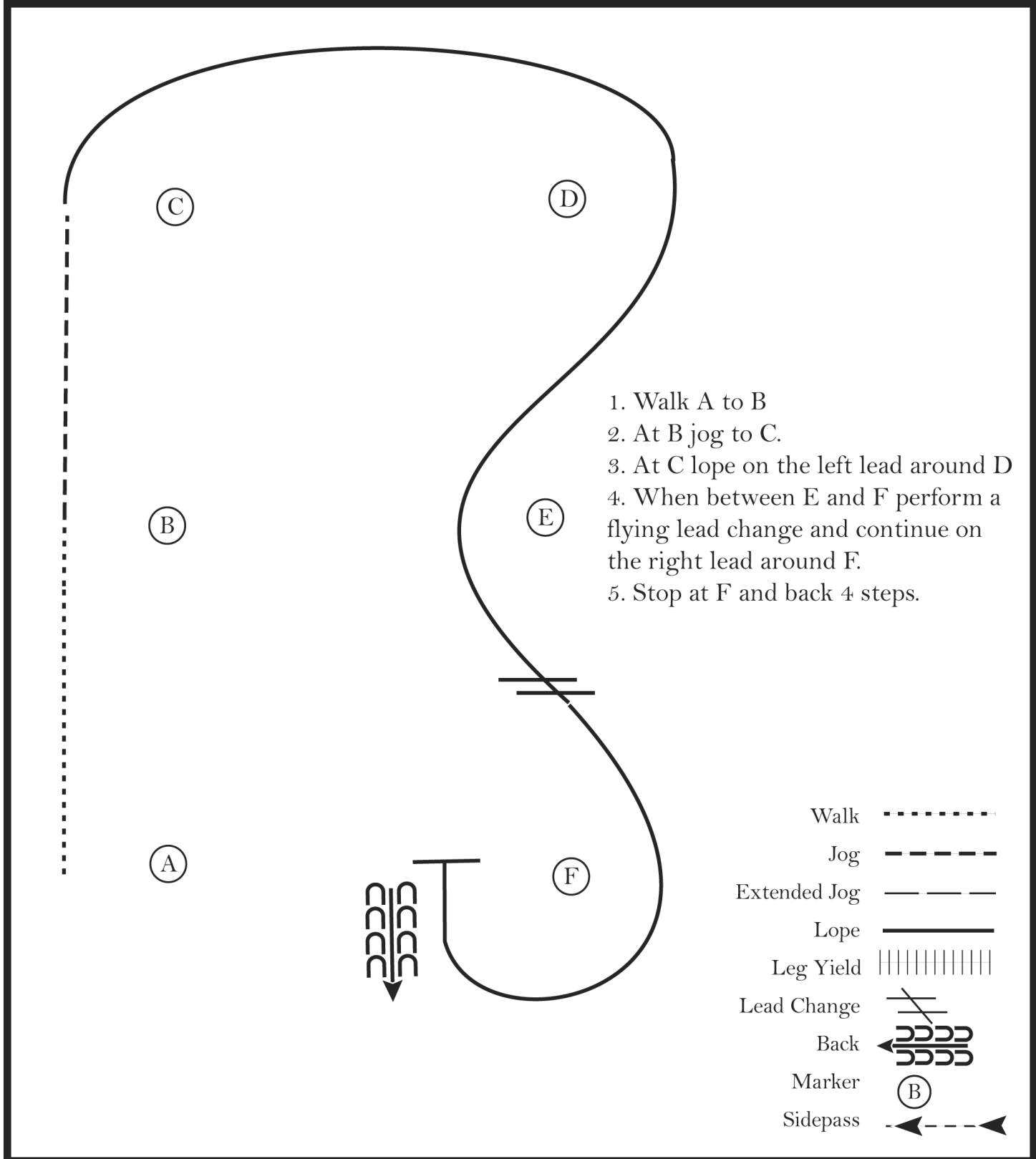

1. Walk A to B
2. At B jog to C.
3. At C lope on the left lead around D
4. When between E and F perform a flying lead change and continue on the right lead around F.
5. Stop at F and back 4 steps.

- Walk (dotted line)
- Jog - - - - - (dashed line)
- Extended Jog - - - - - (long dashed line)
- Lope _____ (solid line)
- Leg Yield ||||| (vertical lines)
- Lead Change / (diagonal lines)
- Back ←←←← (curved arrows pointing left)
- Marker (B) (circle with letter)
- Sidepass ← - - - - → (dashed line with arrowheads)

[WH/2-2]

Pattern Provided by:

Silverado Western Riders

REINING PATTERN 5

End of the year Show Reining Beginner

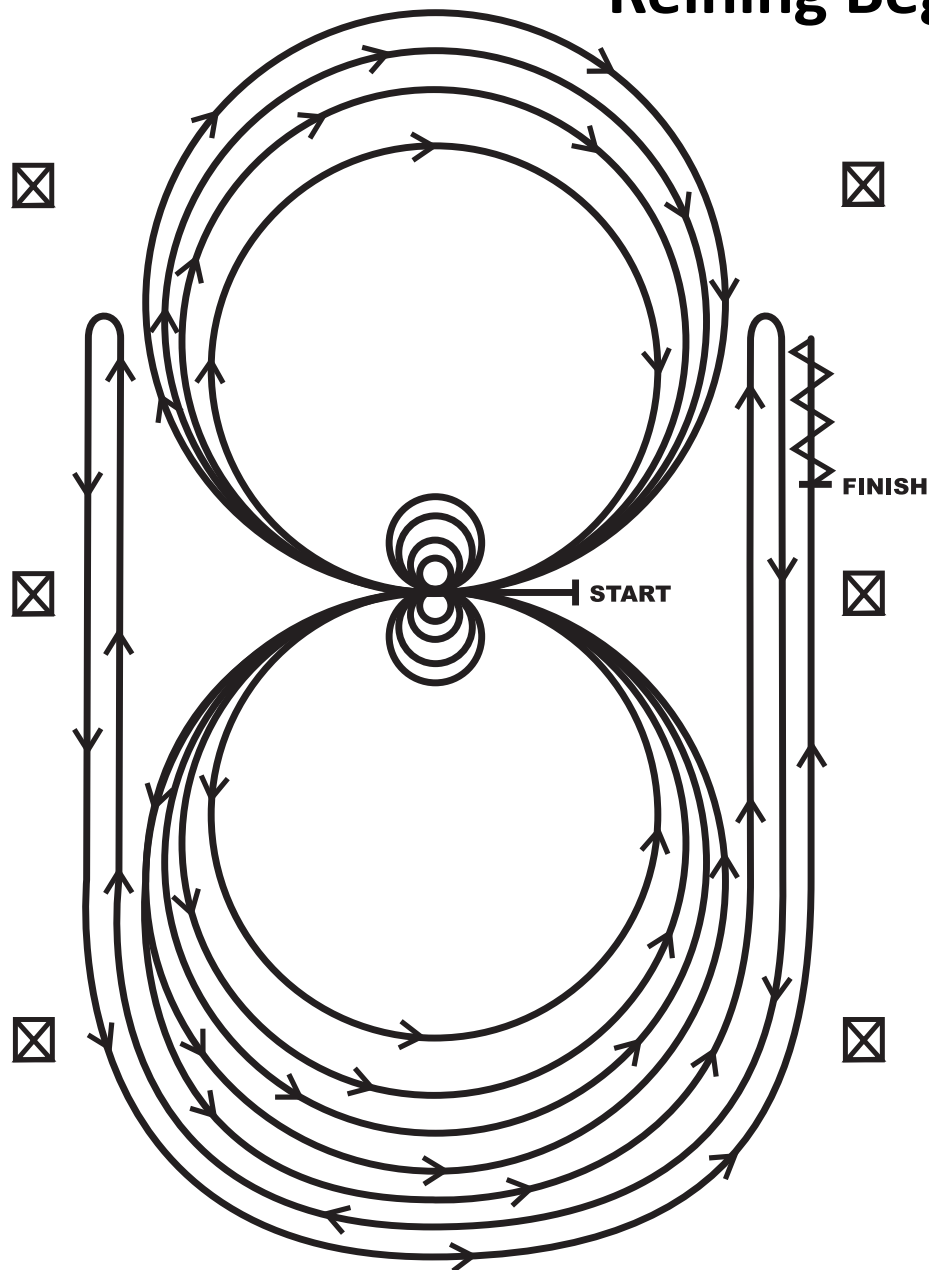

Ekvipasjen kan ri i jog eller skritt til midten av banen. Ekvipasjen skal skritte eller gjøre holdt for å vise hvor mønstret begynner. Begynn midt på banen vendt mot venstre vegg/gjerde.

1. Begynn i venstre galopp og ri tre sirkler til venstre, de to første store og raske, den tredje liten og langsom. Kort opphold.
2. Fullfør fire spin til venstre. Kort opphold.
3. Fatt høyre galopp og ri tre sirkler til høyre, de to første store og raske, den tredje liten og langsom. Kort opphold.
4. Gjør fire spin til høyre. Kort opphold.
5. Fatt venstre galopp og ri en stor rask sirkel til venstre. Bytt galopp midt på banen. Ri en stor rask sirkel til høyre. Bytt galopp midt på banen.
6. Fortsett rundt den tidligere sirkelen til venstre, men ikke avslutt denne, fortsett rett frem langs høyre langside, forbi midt markeringen og gjør en rollback til høyre minst 6 meter fra veggen/gjerde - ikke noe opphold.
7. Fortsett rundt den tidligere sirkelen, men ikke avslutt denne, fortsett rett frem langs venstre langside, forbi midt markeringen og gjør en rollback til venstre minst 6 meter fra vant/gjerdet – ikke noe opphold.
8. Fortsett tilbake rundt den tidligere sirkelen, men ikke avslutt denne, fortsett rett frem langs høyre langside, forbi midt markeringen og gjør en sliding stop minst 6 meter fra veggen/gjerde. Rygg minst 3 meter. Kort opphold for å markere at mønstret er avsluttet

End of the year show

#10 Reining Open

Show Date: 09-28-2024

REINING PATTERN I

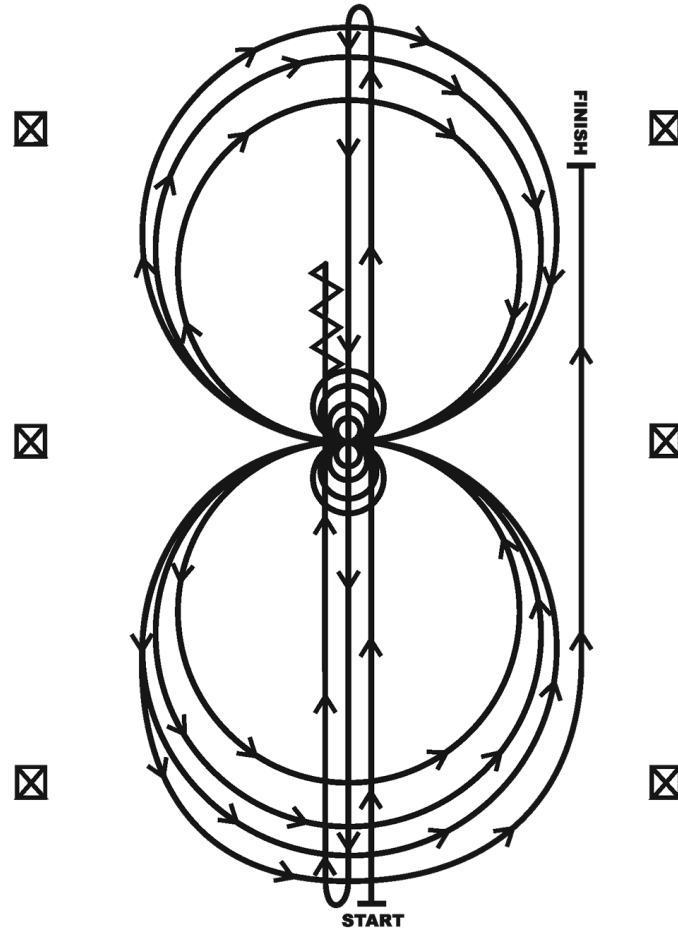

1. Run at speed to the far end of the arena past the endmarker and do a left rollback—no hesitation.
2. Run to the opposite end of the arena past the end marker and do a right rollback—no hesitation.
3. Run past the center marker and do a sliding stop. Back up to center of the arena or at least ten feet (three meters). Hesitate.
4. Complete four spins to the right. Hesitate.
5. Complete four and one-quarter spins to the left so that horse is facing left wall or fence. Hesitate.
6. Beginning on the left lead, complete three circles to the left: the first circle large and fast; the second circle small and slow; the third circle large and fast. Change leads at the center of the arena.
7. Complete three circles to the right: the first circle large and fast; the second circle small and slow; the third circle large and fast. Change leads at the center of the arena.
8. Begin a large circle to the left but do not close this circle. Run straight up the right side of the arena past the center marker and do a sliding stop at least twenty feet (six meters) from wall or fence. Hesitate to demonstrate the completion of the pattern.

[R/AQHAP-1]

Pattern Provided by:

Silverado Western Riders

#11 Trail in hand

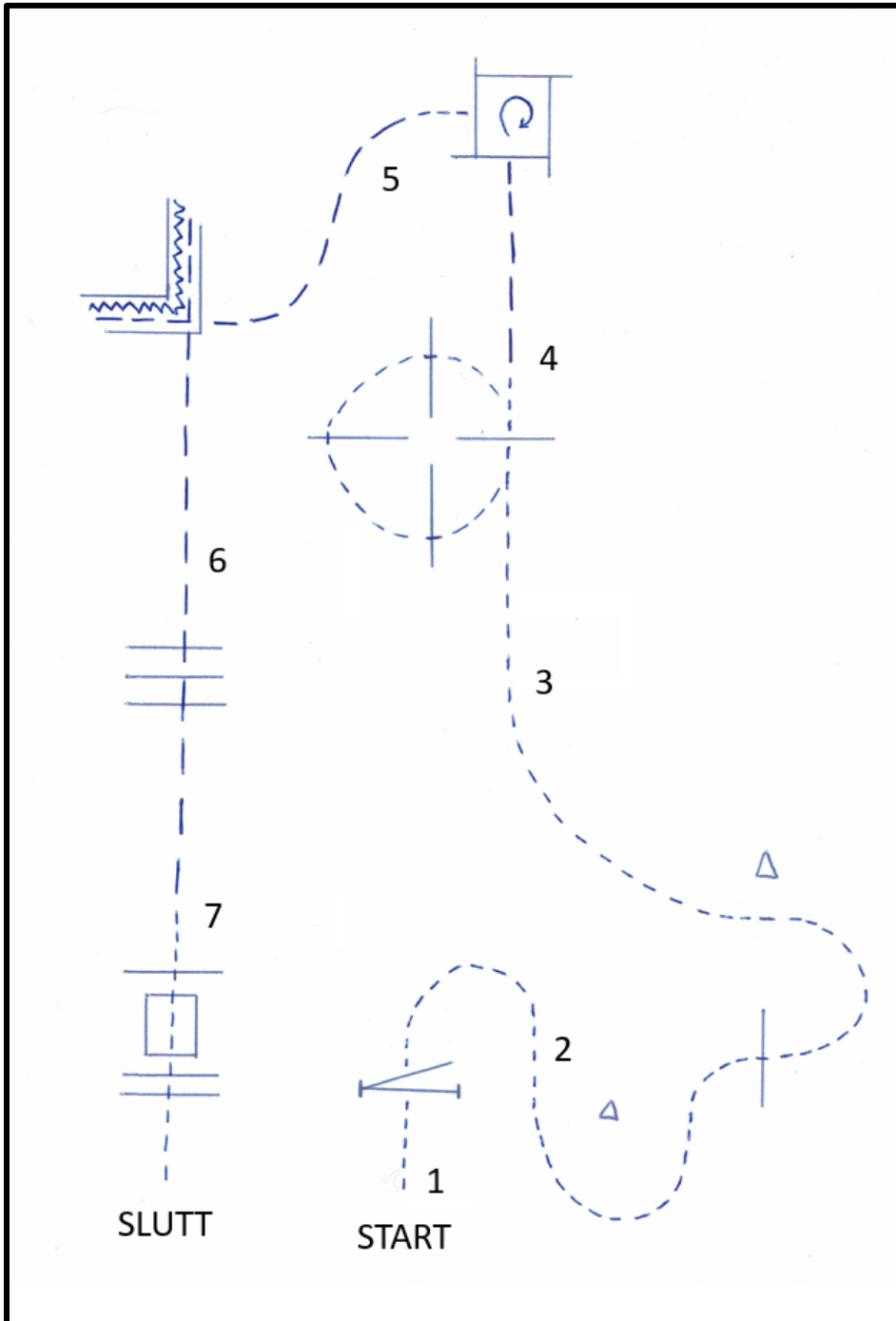

1. Skritt til grind, og ta grinden med venstre hånd.
2. Skritt rundt kjegler og over bom.
3. Skritt over bommer i sirkel.
4. Trav inn i firkant, vend $\frac{3}{4}$ til høyre, og skritt ut.
5. Trav inn i L, rygg L, og trav ut.
6. Trav over bommer.
7. Skritt over bommer og bro.

-----	SKRITT
- - - - -	TRAV
—————	GALOPP
~~~~~	RYGG



## #12 Trail W/T

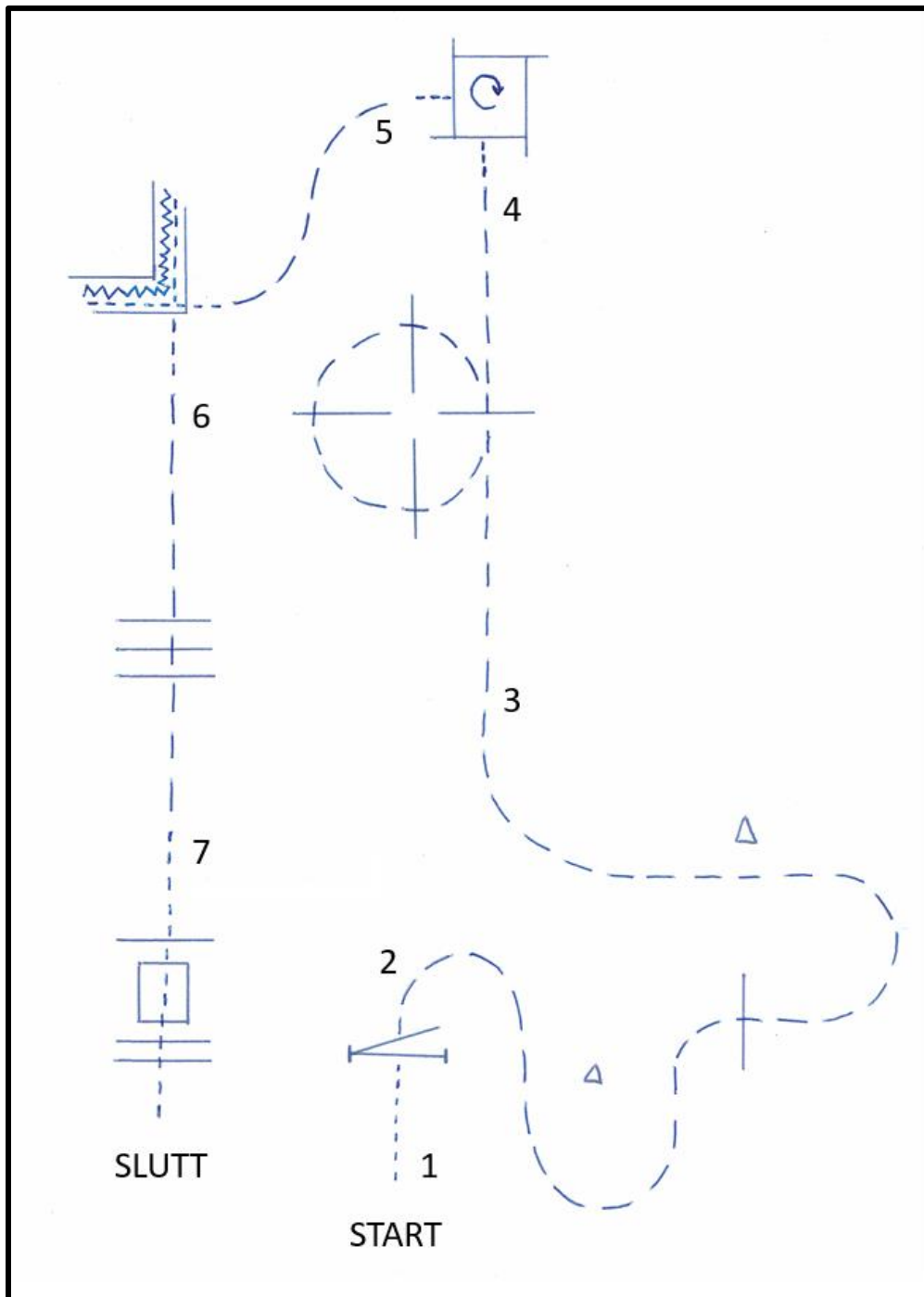

1. Skritt til grind, og ta grinden med venstre hånd.
2. Trav rundt kjepler og over bom.
3. Trav over bommer i sirkel.
4. Skritt inn i firkant, vend  $\frac{3}{4}$  til høyre, og skritt ut.
5. Trav til L, skritt inn, rygg L, og skritt ut.
6. Trav over bommer.
7. Skritt over bommer og bro.

-----	SKRITT
- - - - -	TRAV
—————	GALOPP
~~~~~	RYGG

#13 Trail Beginner

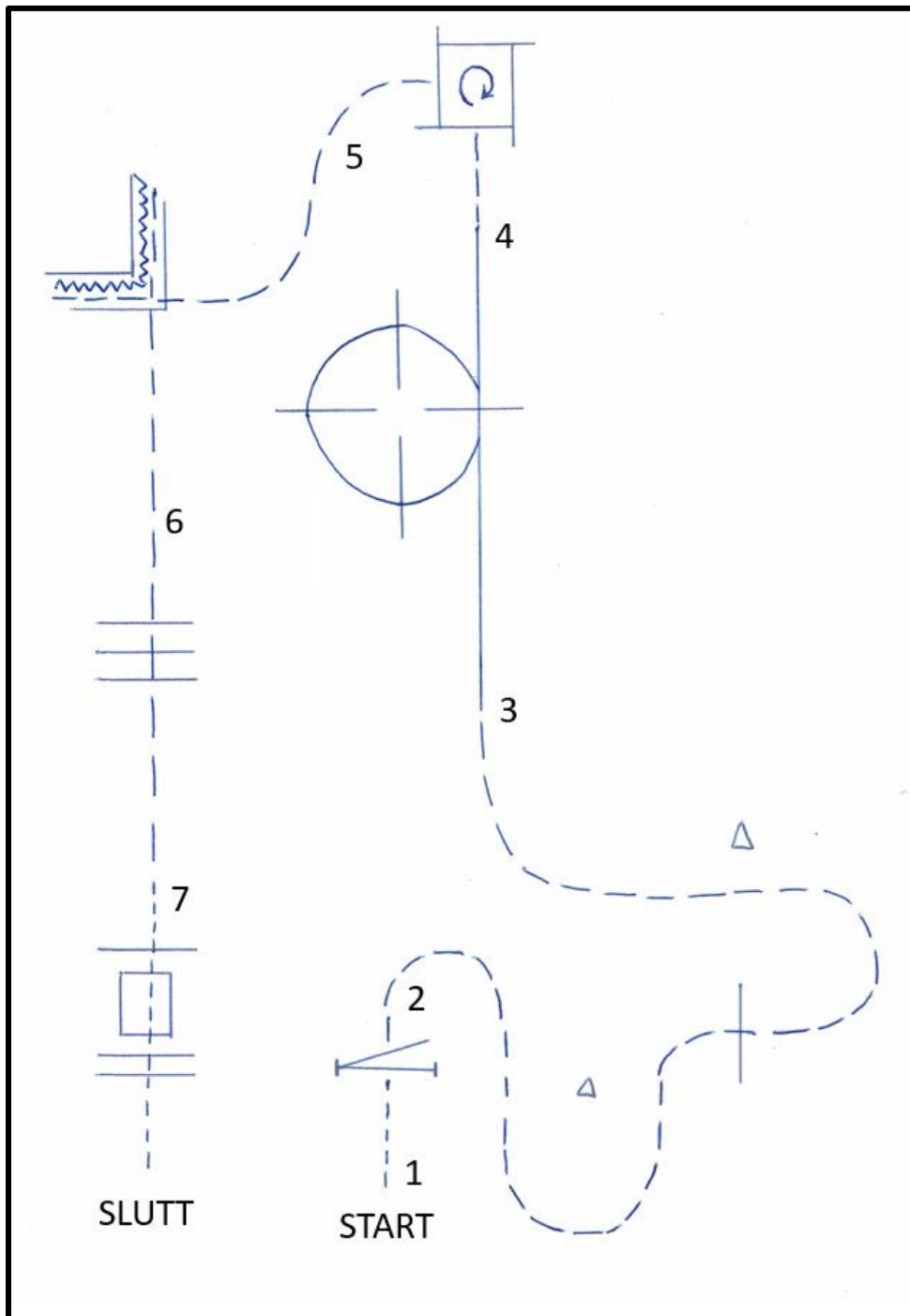

1. Skritt til grind, og ta grinden med venstre hånd.
2. Trav rundt kjepler og over bom.
3. Venstre galopp over bommer i sirkel.
4. Trav inn i firkant, vend $\frac{3}{4}$ til høyre, og trav ut.
5. Trav inn i L, rygg L, og trav ut.
6. Trav over bommer.
7. Skritt over bommer og bro.

-----	SKRITT
- - - - -	TRAV
—————	GALOPP
~~~~~	RYGG

# #14 Trail Open

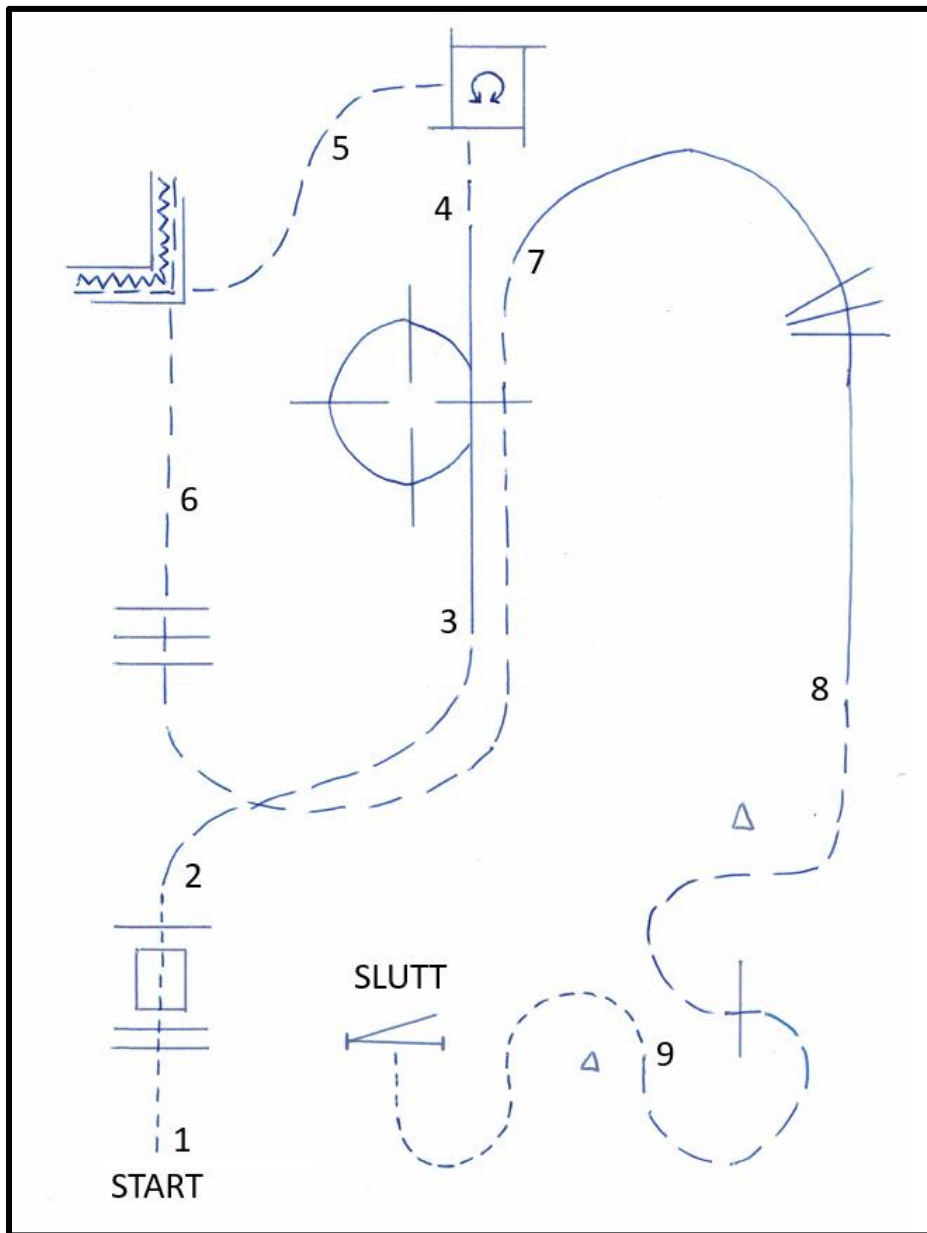

1. Skritt over bommer og bro.
2. Trav til sirkel.
3. Venstre galopp over bommer i sirkel.
4. Trav inn i firkant, vend 360 grader til høyre, vend 90 grader til venstre, og trav ut.
5. Trav inn i L, rygg L, og trav ut.
6. Trav over bommer.
7. Høyre galopp over bommer.
8. Trav rundt kjeGLE og over bom.
9. Skritt til grind, og ta grinden med venstre hånd.

-----	SKRITT
- . - .	TRAV
————	GALOPP
~~~~~	RYGG

Walk Trot Ranch Riding

15

LEGEND	
.....	Walk
.....	Extended Walk
- - - -	Trot
- - - -	Extended Trot
————	Lope
————	Extended Lope
//////	Back
∩	Lead Change

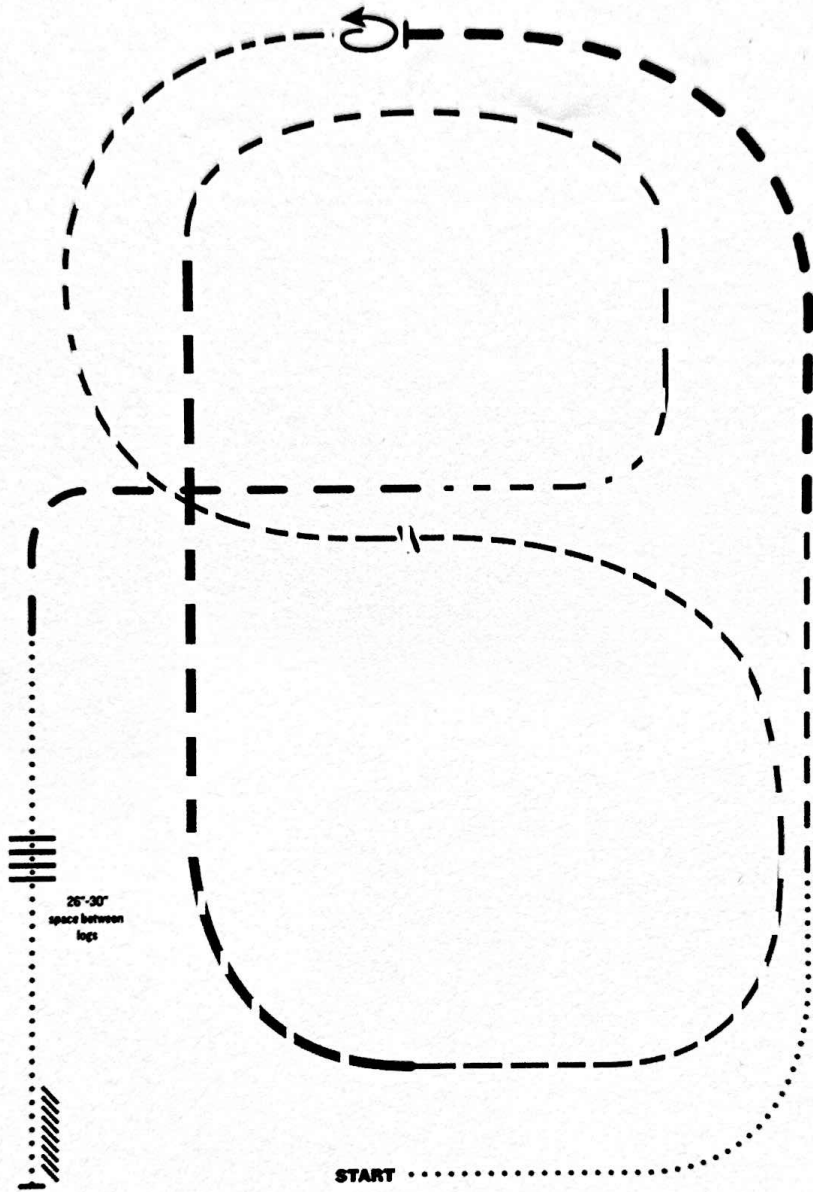

1. Walk
2. Trot
3. Extend trot, at top of the arena, stop
4. 360 turn left.
5. Trot
6. Extend trot up the long side of arena.
7. Trot around top of arena and back to center.
8. Extend trot.
9. Walk over logs
10. Stop and back

Note: The drawn description of this pattern is only intended for the general depiction of the pattern. Exhibitors should utilize the arena space to best exhibit their horses.

Revised 05-2021

End of the year show

#16 Ranch. Riding Beginner

Show Date: 09-28-2024

www.HorseShowPatterns.com

www.HorseShowPatterns.com

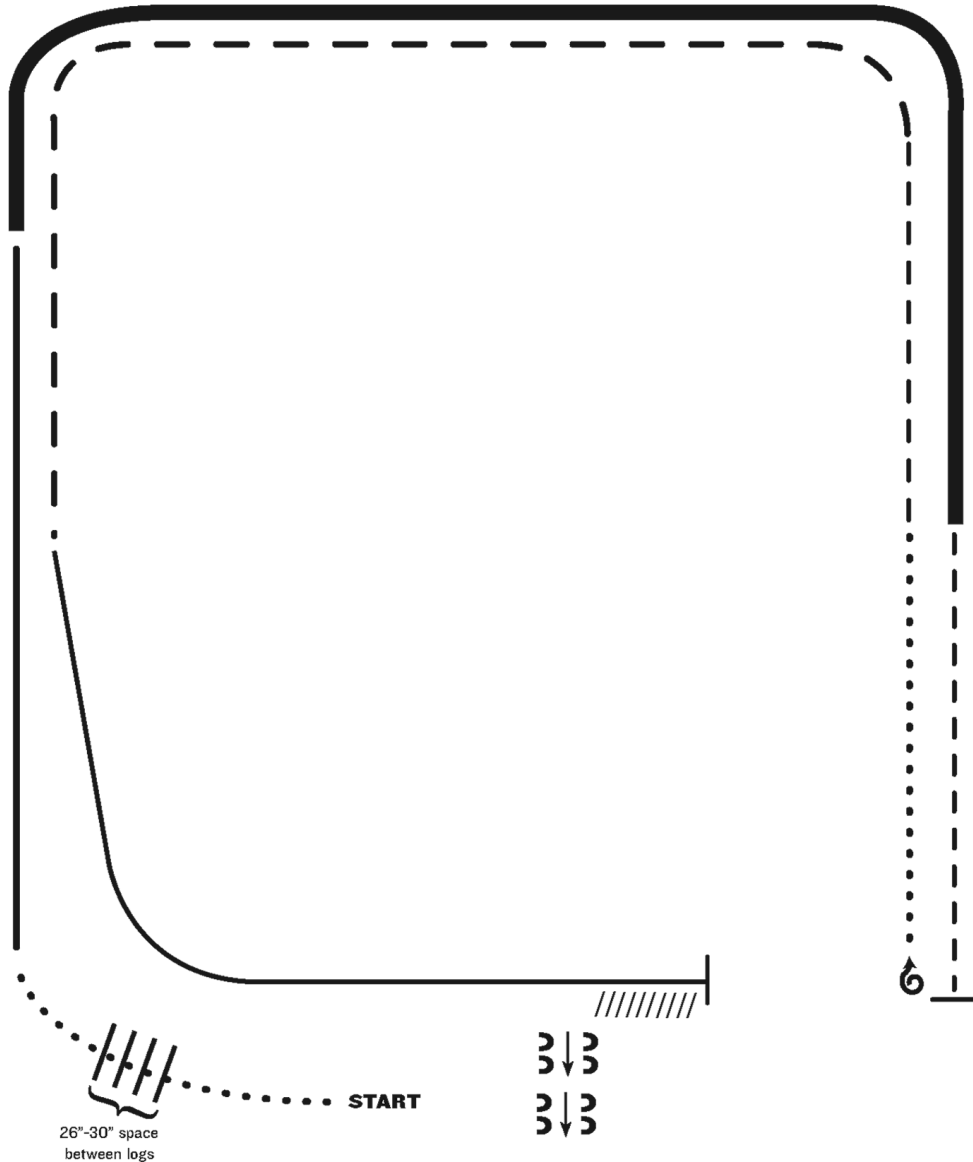

1. Walk
2. Walk over logs
3. Lope right lead
4. Extended lope (right lead)
5. Trot
6. Stop, 1 1/2 turns right
7. Walk
8. Trot
9. Extended trot
10. Lope left lead
11. Stop and Back
12. Side pass right

Note: The drawn description of this pattern is only intended for the general depiction of the pattern. Exhibitors should utilize the arena space to best exhibit their horses.

[RR/AQHA-6]

Pattern Provided by:

Silverado Western Riders

End of the year show

#17 Ranchriding Open

Show Date: 09-28-2024

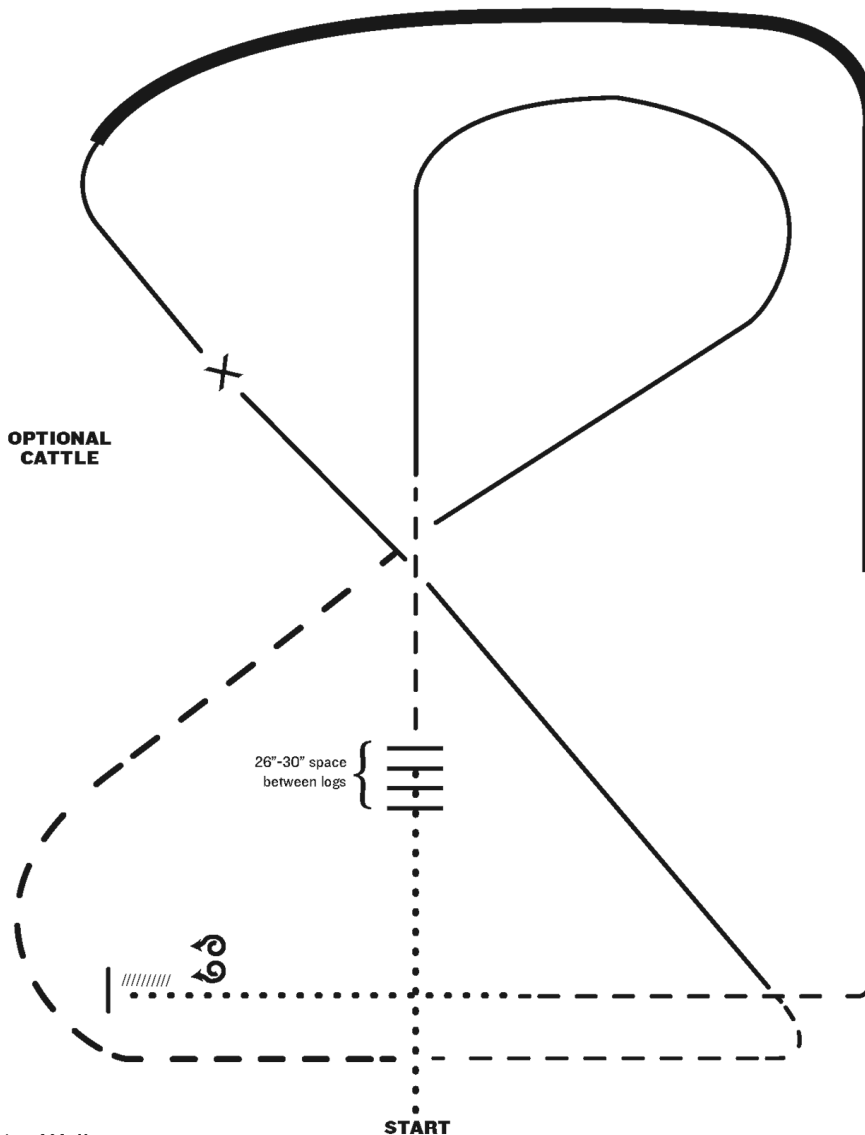

1. Walk
2. Walk over logs
3. Trot
4. Lope right lead
5. Extended trot
6. Trot
7. Lope left lead
8. Change leads (simple or flying)
9. Right lead, extended lope
10. Collect Lope
11. Trot
12. Walk
13. Stop and back
14. 360 degree turn each direction (either direction 1st) (L-R or R-L)

Note: The drawn description of this pattern is only intended for the general depiction of the pattern. Exhibitors should utilize the arena space to best exhibit their horses.

[RR/AQHA-5]

Pattern Provided by:

Silverado Western Riders